

Vassiliev Invariants

(Knot parametrization)

Part II

Evert Stenlund

9₁:

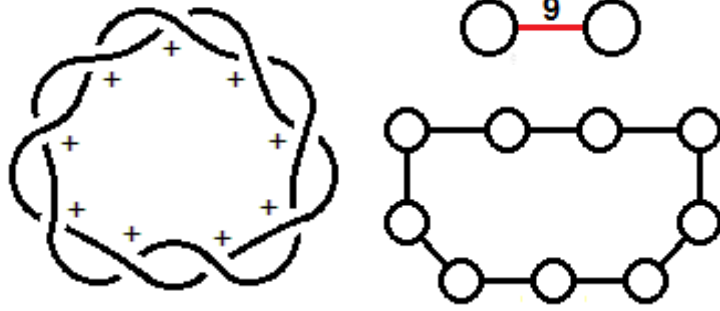

$$v_{even} = x_{9.1}$$

$$v_{odd} = \pm y_{9.1}$$

v_2	$10x_{3.1}$
v_3	$\pm 30y_{3.1}$
v_4	$15x_{5.1} - 35x_{3.1}$
v_5	$\pm(27y_{5.1} - 105y_{3.1})$
v_6	$7x_{7.1} - 20x_{5.1} + 28x_{3.1}$

9_2 :

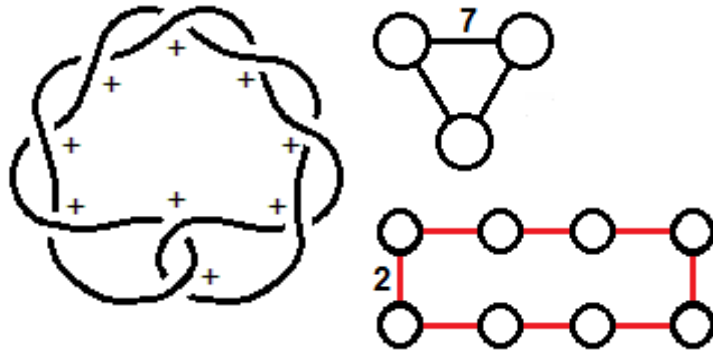

$$v_{even} = x_{9.2}$$

$$v_{odd} = \pm y_{9.2}$$

v_2	$4x_{3.1}$
v_3	$\pm 10y_{3.1}$
v_4	$10x_{5.2} - 4x_{4.1} - 20x_{3.1}$
v_5	$\mp(5y_{6.1} - 15y_{5.2} + 40y_{3.1})$
v_6	$6x_{7.2} - x_{6.1} - 15x_{5.2} + 6x_{4.1} + 20x_{3.1}$

9_3 :

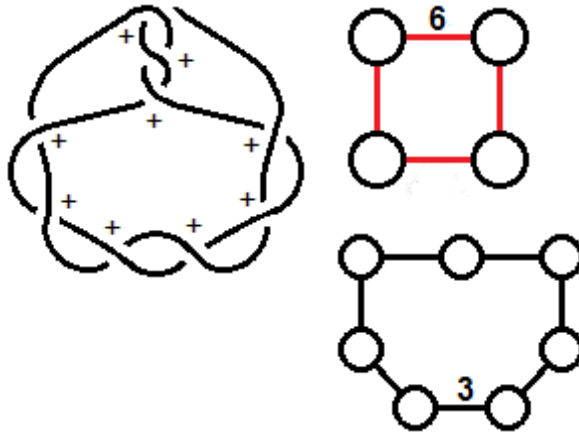

$$v_{\text{even}} = x_{9.3}$$

$$v_{\text{odd}} = \pm y_{9.3}$$

v_2	$9x_{3.1}$
v_3	$\pm 26y_{3.1}$
v_4	$6x_{5.2} + 9x_{5.1} + 3x_{4.1} - 27x_{3.1}$
v_5	$\pm(4y_{6.1} + 10y_{5.2} + 17y_{5.1} - 85y_{3.1})$
v_6	$5x_{7.3} + 2x_{7.1} + x_{6.2} - 10x_{5.2} - 10x_{5.1} - 5x_{4.1} + 18x_{3.1}$

9₄:

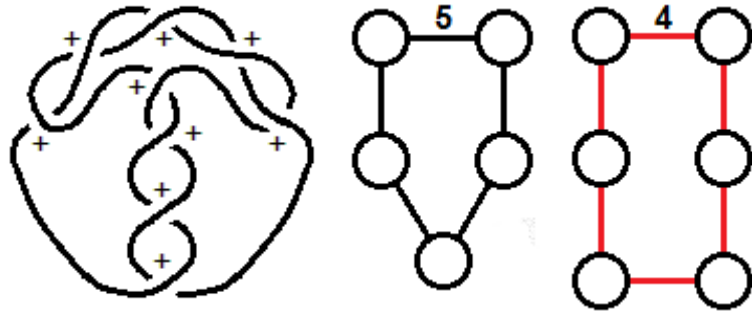

$$v_{\text{even}} = x_{9.4}$$

$$v_{\text{odd}} = \pm y_{9.4}$$

v_2	$7x_{3.1}$
v_3	$\pm 19y_{3.1}$
v_4	$11x_{5.2} + 3x_{5.1} + x_{4.1} - 23x_{3.1}$
v_5	$\pm(3y_{6.2} - 2y_{6.1} + 18y_{5.2} + 6y_{5.1} - 64y_{3.1})$
v_6	$4x_{7.3} + 3x_{7.2} - x_{6.2} + x_{6.1} - 11x_{5.2}$ $- 6x_{5.1} - x_{4.1} + 18x_{3.1}$

9₅:

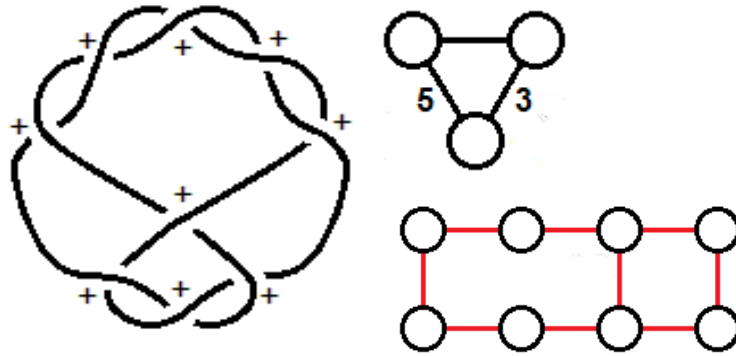

$$v_{\text{even}} = x_{9.5}$$

$$v_{\text{odd}} = \pm y_{9.5}$$

v_2	$6x_{3.1}$
v_3	$\pm 15y_{3.1}$
v_4	$11x_{5.2} + 4x_{4.1} - 12x_{3.1}$
v_5	$\pm(5y_{6.1} + 20y_{5.2} - 40y_{3.1})$
v_6	$-20x_{7.7} + 8x_{7.6} - 8x_{7.5} + 8x_{7.3} + 2x_{7.2} + 8x_{6.3} - 24x_{6.2}$ $+ 9x_{6.1} - 28x_{5.2} - 4x_{5.1} + 34x_{4.1} + 52x_{3.1}$

9_6 :

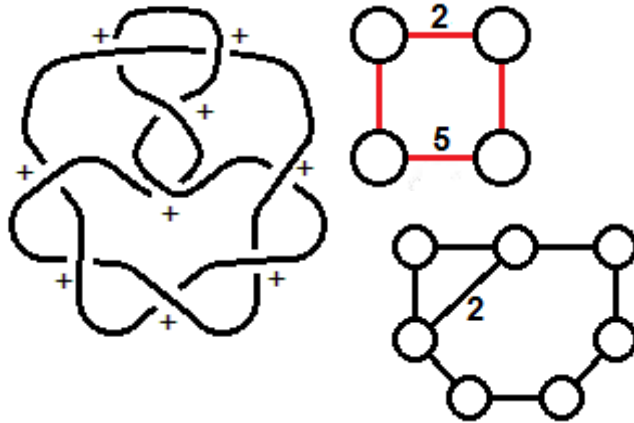

$$v_{\text{even}} = x_{9.6}$$

$$v_{\text{odd}} = \pm y_{9.6}$$

v_2	$7x_{3.1}$
v_3	$\pm 18y_{3.1}$
v_4	$8x_{5.1} - 3x_{4.1} - 20x_{3.1}$
v_5	$\mp(4y_{6.2} - 2y_{5.2} - 11y_{5.1} + 47y_{3.1})$
v_6	$4x_{7.5} - x_{7.3} + 2x_{7.1} - x_{6.3} - x_{6.2}$ $- 2x_{5.2} - 8x_{5.1} + 4x_{4.1} + 16x_{3.1}$

9₇:

$$v_{\text{even}} = x_{9.7}$$

$$v_{\text{odd}} = \pm y_{9.7}$$

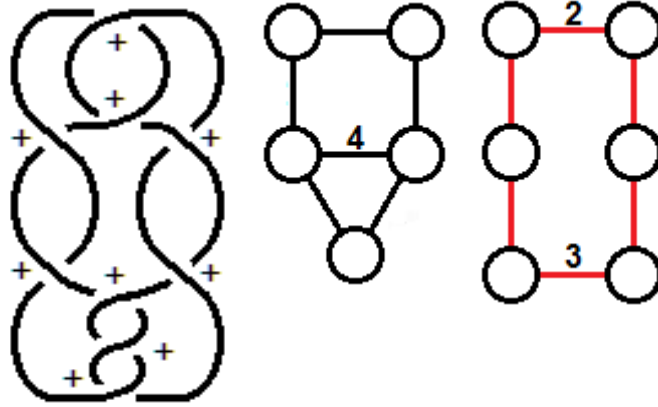

v_2	$5x_{3.1}$
v_3	$\pm 12y_{3.1}$
v_4	$5x_{5.2} + 3x_{5.1} - 4x_{4.1} - 18x_{3.1}$
v_5	$\mp(3y_{6.2} + 2y_{6.1} - 10y_{5.2} - 3y_{5.1} + 38y_{3.1})$
v_6	$-x_{7.6} + 4x_{7.5} + 2x_{7.2} - x_{6.1} - 5x_{5.2}$ $- 6x_{5.1} + 6x_{4.1} + 16x_{3.1}$

9₈:

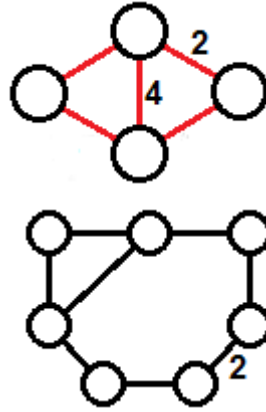
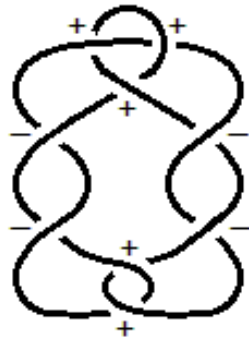

$$v_{\text{even}} = x_{9.8}$$

$$v_{\text{odd}} = \pm y_{9.8}$$

v_2	0
v_3	$\pm 2y_{3.1}$
v_4	$5x_{5.2} - 2x_{5.1} + x_{4.1} - 3x_{3.1}$
v_5	$\mp(3y_{6.2} - 3y_{6.1} - 5y_{5.2} + 2y_{5.1} + 3y_{3.1})$
v_6	$4x_{7.6} - x_{7.5} + x_{7.2} - 10x_{5.2} + 4x_{5.1}$ $+ x_{4.1} + 6x_{3.1}$

9₉:

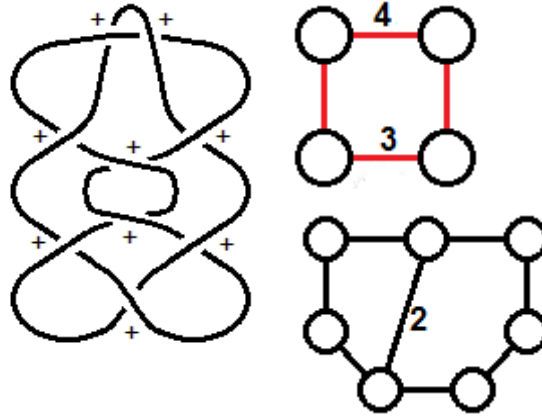

$$v_{\text{even}} = x_{9.9}$$

$$v_{\text{odd}} = \pm y_{9.9}$$

v_2	$8x_{3.1}$
v_3	$\pm 22y_{3.1}$
v_4	$4x_{5.2} + 8x_{5.1} - 24x_{3.1}$
v_5	$\pm(8y_{5.2} + 13y_{5.1} - 67y_{3.1})$
v_6	$2x_{7.5} + 2x_{7.3} + 2x_{7.1} + x_{6.3} - 2x_{5.2}$ $- 11x_{5.1} + x_{4.1} + 15x_{3.1}$

9₁₀:

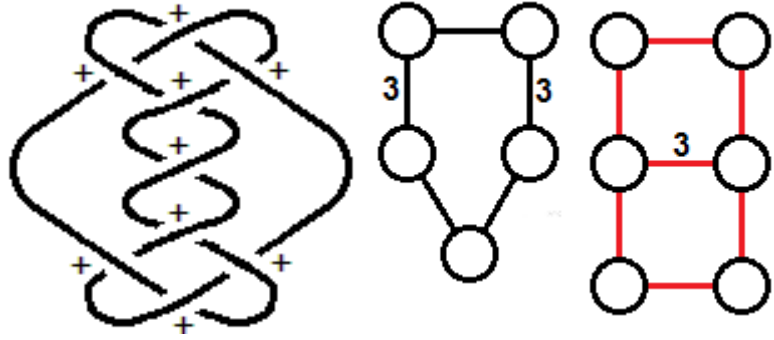

$$v_{even} = x_{9.10}$$

$$v_{odd} = \pm y_{9.10}$$

v_2	$8x_{3.1}$
v_3	$\pm 22y_{3.1}$
v_4	$10x_{5.2} + 4x_{5.1} + 6x_{4.1} - 18x_{3.1}$
v_5	$\pm(4y_{6.2} + 4y_{6.1} + 18y_{5.2} + 8y_{5.1} - 64y_{3.1})$
v_6	$-14x_{7.7} + 6x_{7.6} - 6x_{7.5} + 10x_{7.3} + 6x_{6.3} - 16x_{6.2}$ $+ 6x_{6.1} - 26x_{5.2} - 6x_{5.1} + 20x_{4.1} + 42x_{3.1}$

9₁₁:

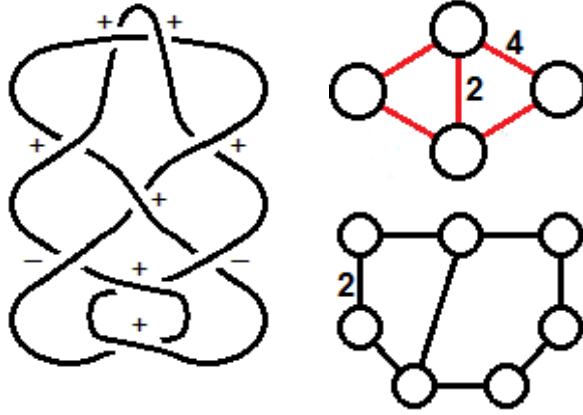

$$v_{\text{even}} = x_{9.11}$$

$$v_{\text{odd}} = \pm y_{9.11}$$

v_2	$4x_{3.1}$
v_3	$\pm 9y_{3.1}$
v_4	$8x_{5.2} - x_{5.1} + x_{4.1} - 8x_{3.1}$
v_5	$\mp(y_{6.2} - 2y_{6.1} - 11y_{5.2} + y_{5.1} + 18y_{3.1})$
v_6	$3x_{7.6} + x_{7.5} + 2x_{7.3} - x_{7.1} - x_{6.3} - x_{6.2} + x_{6.1}$ $- 8x_{5.2} + x_{5.1} - 2x_{4.1} + 6x_{3.1}$

9_{12} :

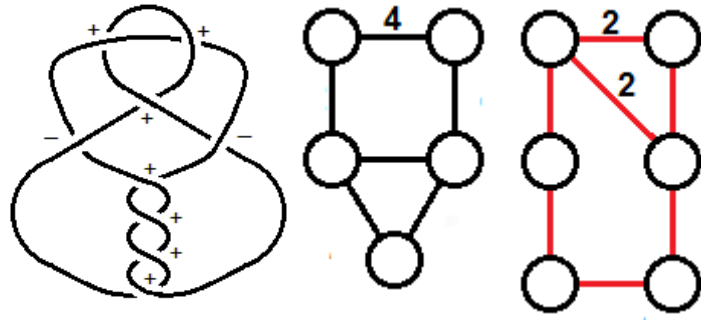

$$v_{\text{even}} = x_{9.12}$$

$$v_{\text{odd}} = \pm y_{9.12}$$

v_2	$x_{3.1}$
v_3	$\pm 3y_{3.1}$
v_4	$7x_{5.2} - 2x_{5.1} - x_{4.1} - 8x_{3.1}$
v_5	$\mp(3y_{6.2} - 2y_{6.1} - 10y_{5.2} + 3y_{5.1} + 13y_{3.1})$
v_6	$-5x_{7.7} + 5x_{7.6} - 2x_{7.5} + x_{7.3} + 2x_{7.2} + 3x_{6.3} - 5x_{6.2} + x_{6.1} - 15x_{5.2} + 2x_{5.1} + 12x_{4.1} + 18x_{3.1}$

9_{13} :

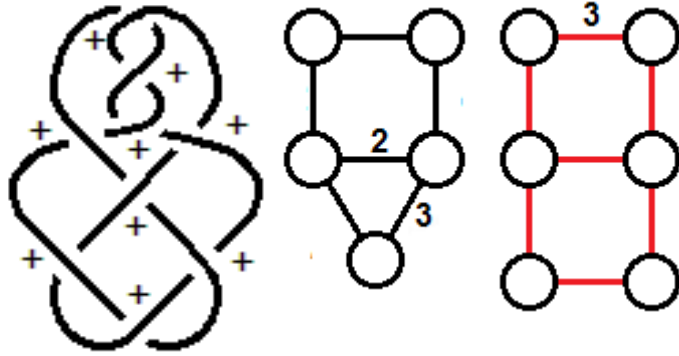

$$v_{\text{even}} = x_{9.13}$$

$$v_{\text{odd}} = \pm y_{9.13}$$

v_2	$7x_{3.1}$
v_3	$\pm 18y_{3.1}$
v_4	$6x_{5.2} + 4x_{5.1} + 3x_{4.1} - 14x_{3.1}$
v_5	$\pm(4y_{6.1} + 12y_{5.2} + 6y_{5.1} - 44y_{3.1})$
v_6	$-10x_{7.7} + 5x_{7.6} - 2x_{7.5} + 6x_{7.3} - x_{7.2} + 5x_{6.3} - 11x_{6.2}$ $+ 4x_{6.1} - 16x_{5.2} - 5x_{5.1} + 16x_{4.1} + 28x_{3.1}$

9₁₄:

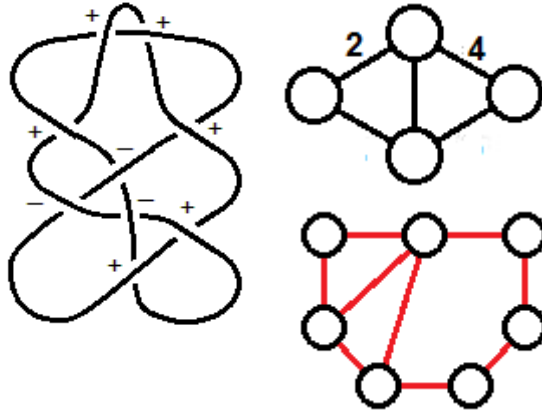

$$v_{\text{even}} = x_{9.14}$$

$$v_{\text{odd}} = \pm y_{9.14}$$

v_2	$-x_{3.1}$
v_3	$\mp 2y_{3.1}$
v_4	$-5x_{5.2} + 2x_{5.1} + 3x_{3.1}$
v_5	$\pm(5y_{6.2} - 5y_{6.1} - 7y_{5.2} + 3y_{5.1} + 4y_{3.1})$
v_6	$8x_{7.7} - 2x_{7.6} + 2x_{7.5} - x_{7.3} - x_{7.2} - 2x_{6.3} + 6x_{6.2}$ $- 2x_{6.1} + 10x_{5.2} - 2x_{5.1} - 10x_{4.1} - 11x_{3.1}$

9_{15} :

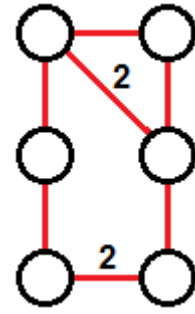
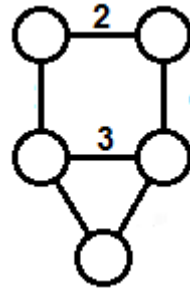
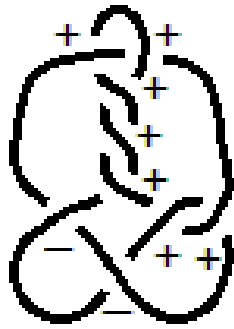

$$v_{\text{even}} = x_{9.15}$$

$$v_{\text{odd}} = \pm y_{9.15}$$

v_2	$2x_{3.1}$
v_3	$\pm 5y_{3.1}$
v_4	$8x_{5.2} - 2x_{5.1} - x_{4.1} - 9x_{3.1}$
v_5	$\mp(y_{6.2} - 9y_{5.2} + 2y_{5.1} + 13y_{3.1})$
v_6	$x_{7.7} + 4x_{7.6} - x_{7.5} + 2x_{7.2} - 9x_{5.2}$ $+ 3x_{5.1} + 6x_{3.1}$

9_{16} :

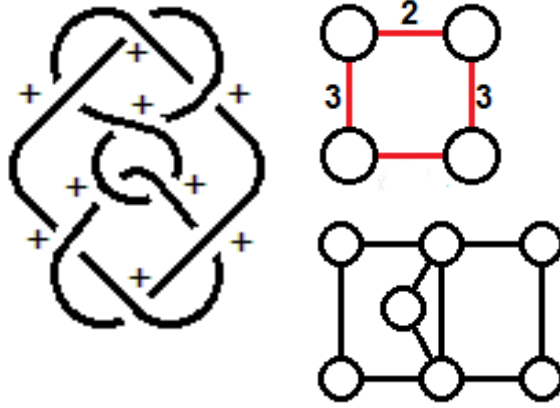

$$v_{\text{even}} = x_{9.16}$$

$$v_{\text{odd}} = \pm y_{9.16}$$

v_2	$6x_{3.1}$
v_3	$\pm 14y_{3.1}$
v_4	$-3x_{5.2} + 7x_{5.1} - 3x_{4.1} - 12x_{3.1}$
v_5	$\mp(10y_{6.2} - 8y_{6.1} - 2y_{5.2} - 6y_{5.1} + 24y_{3.1})$
v_6	$\frac{1}{8}(-116x_{7.7} + 95x_{7.6} - 2x_{7.5} + 16x_{7.3} - 33x_{7.2} + 16x_{7.1} + 79x_{6.3} - 157x_{6.2} + 62x_{6.1} - 78x_{5.2} - 77x_{5.1} + 227x_{4.1} + 270x_{3.1})$

9₁₇:

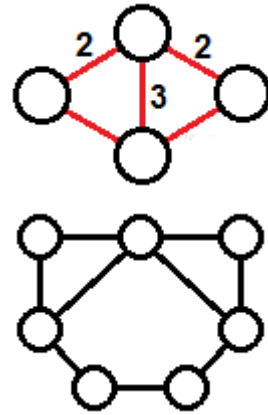

$$v_{\text{even}} = x_{9.17}$$

$$v_{\text{odd}} = \pm y_{9.17}$$

v_2	$-2x_{3.1}$
v_3	0
v_4	$-2x_{5.2} + x_{5.1} + 2x_{4.1} + x_{3.1}$
v_5	$\mp(4y_{6.2} - 4y_{6.1} - 2y_{5.2} + y_{5.1} + y_{3.1})$
v_6	$-2x_{7.7} + 2x_{7.6} - 2x_{7.5} + x_{7.1} + 2x_{6.3} - 6x_{6.2} + 2x_{6.1}$ $+ 2x_{5.2} - 4x_{5.1} + 12x_{4.1} + 12x_{3.1}$

9_{18} :

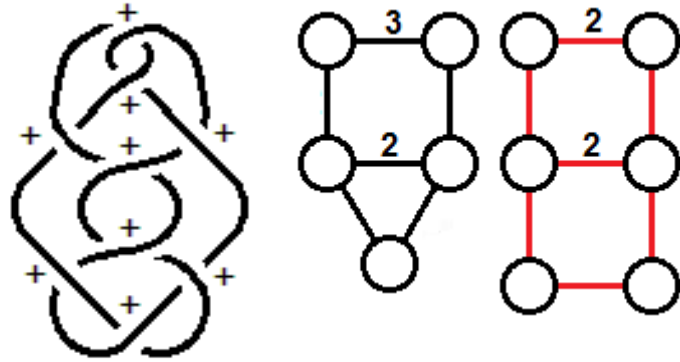

$$v_{\text{even}} = x_{9.18}$$

$$v_{\text{odd}} = \pm y_{9.18}$$

v_2	$6x_{3.1}$
v_3	$\pm 15y_{3.1}$
v_4	$5x_{5.2} + 4x_{5.1} - 2x_{4.1} - 18x_{3.1}$
v_5	$\mp(3y_{6.1} - 8y_{5.2} - 6y_{5.1} + 42y_{3.1})$
v_6	$4x_{7.7} - 3x_{7.6} + 4x_{7.5} + 2x_{7.2} - 3x_{6.3} + 5x_{6.2}$ $- 2x_{6.1} - 3x_{5.2} - 3x_{5.1} - 6x_{4.1} + 4x_{3.1}$

9₁₉:

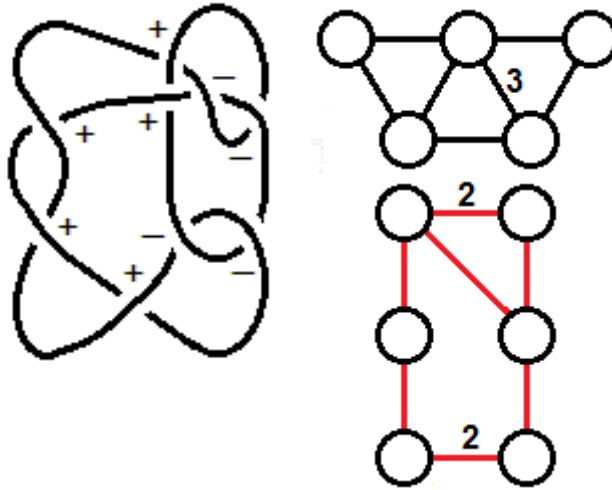

$$v_{\text{even}} = x_{9.19}$$

$$v_{\text{odd}} = \pm y_{9.19}$$

v_2	$-2x_{3.1}$
v_3	$\pm y_{3.1}$
v_4	$-4x_{5.2} + 2x_{5.1} + x_{4.1} + x_{3.1}$
v_5	$\mp(5y_{6.2} - 5y_{6.1} - 4y_{5.2} + 2y_{5.1} + y_{3.1})$
v_6	$3x_{7.7} + x_{7.5} - x_{7.2} + 5x_{5.2} - 3x_{5.1} + x_{4.1}$

9_{20} :

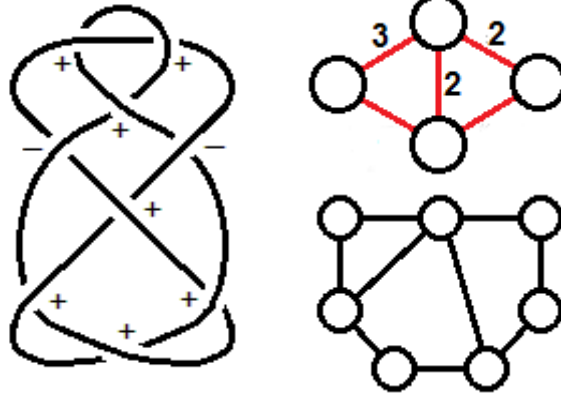

$$v_{\text{even}} = x_{9.20}$$

$$v_{\text{odd}} = \pm y_{9.20}$$

v_2	$2x_{3.1}$
v_3	$\pm 4y_{3.1}$
v_4	$5x_{5.2} - x_{5.1} - x_{4.1} - 6x_{3.1}$
v_5	$\mp(3y_{6.2} - 2y_{6.1} - 8y_{5.2} + 2y_{5.1} + 11y_{3.1})$
v_6	$2x_{7.6} + 3x_{7.5} + x_{7.3} - x_{7.2} - x_{7.1} + x_{6.3} + x_{6.2} - x_{6.1}$ $- 3x_{5.2} - 2x_{5.1} + 2x_{4.1} + 4x_{3.1}$

9_{21} :

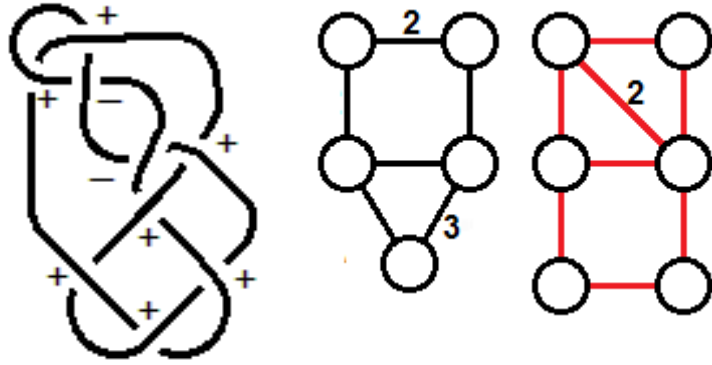

$$v_{\text{even}} = x_{9.21}$$

$$v_{\text{odd}} = \pm y_{9.21}$$

v_2	$3x_{3.1}$
v_3	$\pm 6y_{3.1}$
v_4	$7x_{5.2} - 2x_{5.1} + 2x_{4.1} - 3x_{3.1}$
v_5	$\mp(3y_{6.2} - 5y_{6.1} - 11y_{5.2} + 3y_{5.1} + 10y_{3.1})$
v_6	$-11x_{7.7} + 5x_{7.6} - 4x_{7.5} + 3x_{7.3} + x_{7.2} + 3x_{6.3} - 13x_{6.2}$ $+ 5x_{6.1} - 15x_{5.2} + 18x_{4.1} + 27x_{3.1}$

9_{22} :

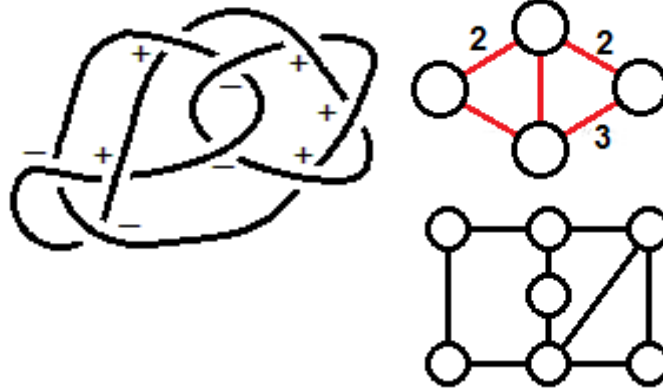

$$v_{\text{even}} = x_{9.22}$$

$$v_{\text{odd}} = \pm y_{9.22}$$

v_2	$-x_{3.1}$
v_3	$\pm y_{3.1}$
v_4	$-x_{5.2} + x_{5.1} - x_{4.1} - 3x_{3.1}$
v_5	$\mp(6y_{6.2} - 6y_{6.1} - 4y_{5.2} + 2y_{5.1} + y_{3.1})$
v_6	$\frac{1}{8}(12x_{7.7} + 21x_{7.6} - 6x_{7.5} - 4x_{7.3} - 7x_{7.2} + 8x_{7.1} + 21x_{6.3} - 19x_{6.2} - 2x_{6.1} + 58x_{5.2} - 43x_{5.1} + 69x_{4.1} + 38x_{3.1})$

9_{23} :

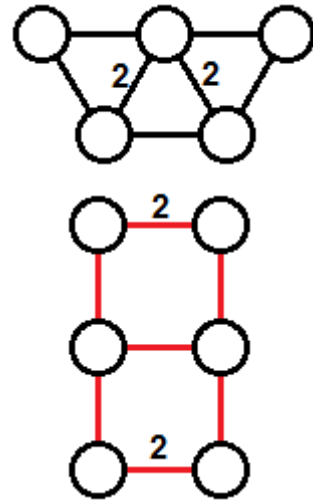

$$v_{\text{even}} = x_{9.23}$$

$$v_{\text{odd}} = \pm y_{9.23}$$

v_2	$5x_{3.1}$
v_3	$\pm 11y_{3.1}$
v_4	$4x_{5.1} - 2x_{4.1} - 9x_{3.1}$
v_5	$\mp(4y_{6.2} - 2y_{6.1} - 2y_{5.2} - 4y_{5.1} + 17y_{3.1})$
v_6	$x_{7.7} + 2x_{7.6} + 4x_{7.5} - 2x_{7.2} - 3x_{5.1} + 3x_{3.1}$

9_{24} :

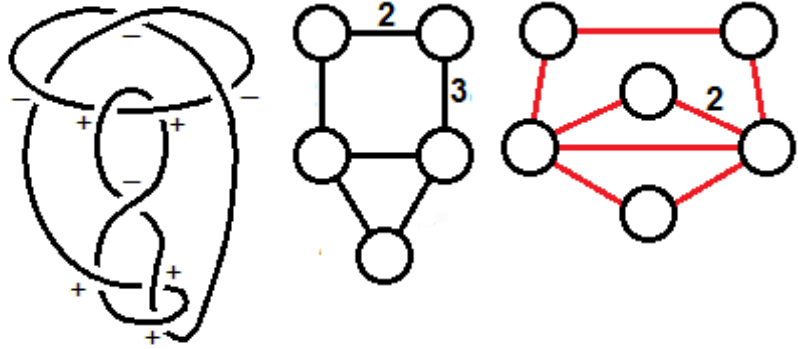

$$v_{\text{even}} = x_{9.24}$$

$$v_{\text{odd}} = \pm y_{9.24}$$

v_2	$x_{3.1}$
v_3	$\pm 2y_{3.1}$
v_4	$2x_{5.2} - x_{5.1} + x_{4.1} + x_{3.1}$
v_5	$\mp(5y_{6.2} - 6y_{6.1} - 4y_{5.2} + 2y_{5.1} - y_{3.1})$
v_6	$\frac{1}{8}(-4x_{7.7} + 23x_{7.6} + 6x_{7.5} + 8x_{7.3} - x_{7.2} - 8x_{7.1} - 9x_{6.3} + 3x_{6.2} + 6x_{6.1} - 102x_{5.2} + 43x_{5.1} - 37x_{4.1} + 30x_{3.1})$

9₂₅:

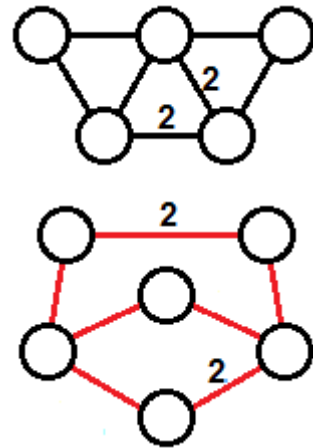
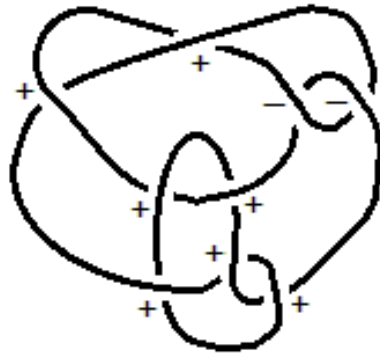

$$v_{\text{even}} = x_{9.25}$$

$$v_{\text{odd}} = \pm y_{9.25}$$

v_2	0
v_3	$\pm y_{3.1}$
v_4	$7x_{5.2} - 3x_{5.1} + 2x_{4.1} - 3x_{3.1}$
v_5	$\pm(3y_{6.2} - 4y_{6.1} + 5y_{5.2} - y_{5.1} - 10y_{3.1})$
v_6	$\frac{1}{8}(4x_{7.7} - 3x_{7.6} - 6x_{7.5} - 4x_{7.3} + 25x_{7.2} - 3x_{6.3} + 29x_{6.2} - 26x_{6.1} - 70x_{5.2} + 21x_{5.1} + 53x_{4.1} + 86x_{3.1})$

9₂₆:

$$v_{\text{even}} = x_{9.26}$$

$$v_{\text{odd}} = \pm y_{9.26}$$

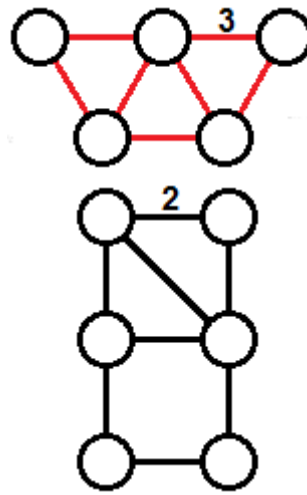

v_2	0
v_3	$\mp y_{3.1}$
v_4	$-3x_{5.2} + x_{5.1} + 3x_{3.1}$
v_5	$\pm(4y_{6.2} - 4y_{6.1} - 5y_{5.2} + 2y_{5.1} + 4y_{3.1})$
v_6	$2x_{7.7} - x_{7.6} - 2x_{7.5} - x_{7.3} + x_{7.2} + x_{7.1}$ $+ 5x_{5.2} - x_{5.1}$

9₂₇:

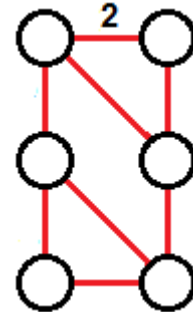
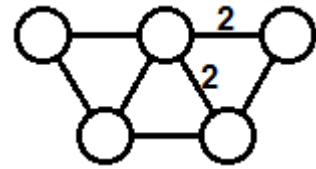

$$v_{\text{even}} = x_{9.27}$$

$$v_{\text{odd}} = \pm y_{9.27}$$

v_2	0
v_3	$\pm y_{3.1}$
v_4	$2x_{5.2} - x_{5.1} + x_{4.1}$
v_5	$\mp(3y_{6.2} - 3y_{6.1} - 2y_{5.2} + y_{5.1})$
v_6	$4x_{7.7} + 3x_{7.5} - x_{7.2} - x_{7.1} - 2x_{6.3} + 6x_{6.2}$ $- 2x_{6.1} - x_{5.2} + 2x_{5.1} - 9x_{4.1} - 8x_{3.1}$

9₂₈:

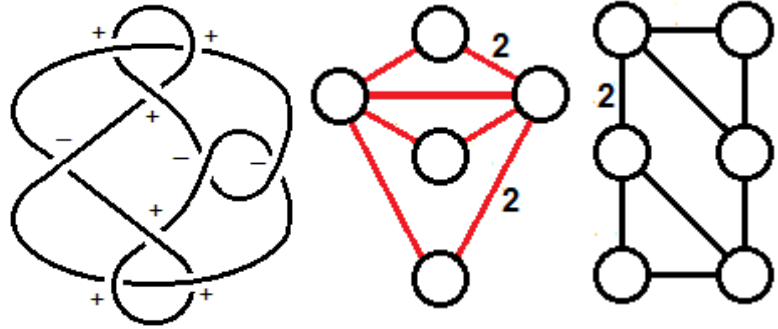

$$v_{\text{even}} = x_{9.28}$$

$$v_{\text{odd}} = \pm y_{9.28}$$

v_2	$x_{3.1}$
v_3	0
v_4	$-3x_{5.2} + x_{5.1} + 4x_{3.1}$
v_5	$\pm(y_{6.1} - y_{5.2} + 4y_{3.1})$
v_6	$\frac{1}{8}(-20x_{7.7} + 15x_{7.6} - 26x_{7.5} + 7x_{7.2} + 8x_{7.1} + 23x_{6.3} - 37x_{6.2} + 14x_{6.1} - 14x_{5.2} - 5x_{5.1} + 59x_{4.1} + 78x_{3.1})$

9₂₉:

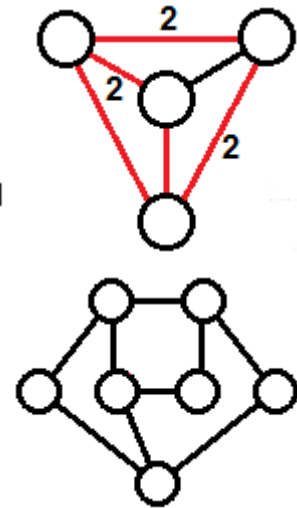
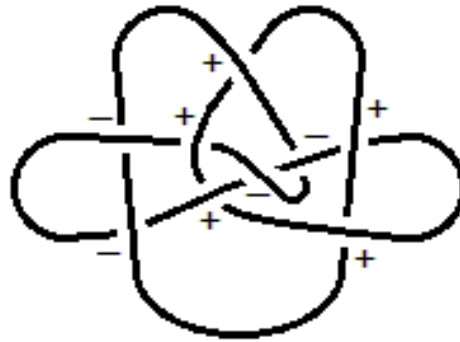

$$v_{\text{even}} = x_{9.29}$$

$$v_{\text{odd}} = \pm y_{9.29}$$

v_2	$x_{3.1}$
v_3	$\pm 2y_{3.1}$
v_4	$-x_{5.2} + x_{5.1} - 2x_{4.1} - 2x_{3.1}$
v_5	$\mp(10y_{6.2} - 12y_{6.1} - 8y_{5.2} + 4y_{5.1})$
v_6	$\frac{1}{8}(36x_{7.7} + 23x_{7.6} + 6x_{7.5} - 8x_{7.3} - 17x_{7.2} + 8x_{7.1} + 31x_{6.3} + 11x_{6.2} - 10x_{6.1} + 122x_{5.2} - 61x_{5.1} + 19x_{4.1} - 42x_{3.1})$

9₃₀:

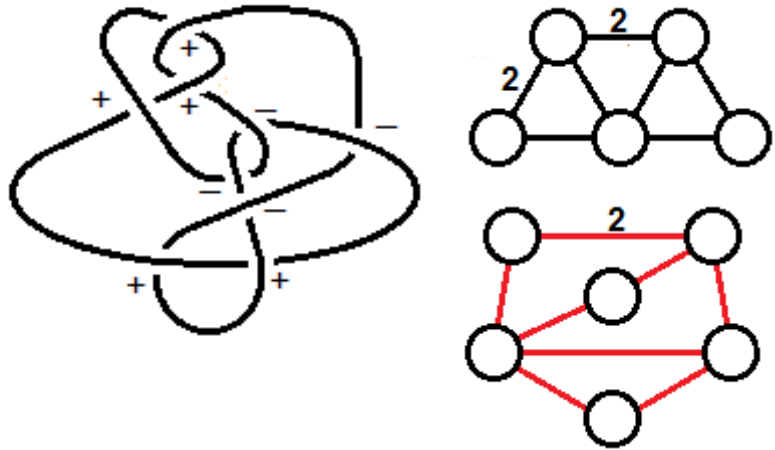

$$v_{\text{even}} = x_{9.30}$$

$$v_{\text{odd}} = \pm y_{9.30}$$

v_2	$-x_{3.1}$
v_3	$\pm y_{3.1}$
v_4	$2x_{5.2} - x_{5.1} + 2x_{4.1}$
v_5	$\mp y_{6.2}$
v_6	$\frac{1}{8}(4x_{7.7} + 13x_{7.6} + 10x_{7.5} + 4x_{7.3} + x_{7.2} - 8x_{7.1} - 11x_{6.3} + 21x_{6.2} - 2x_{6.1} - 86x_{5.2} + 45x_{5.1} - 43x_{4.1} - 10x_{3.1})$

9₃₁:

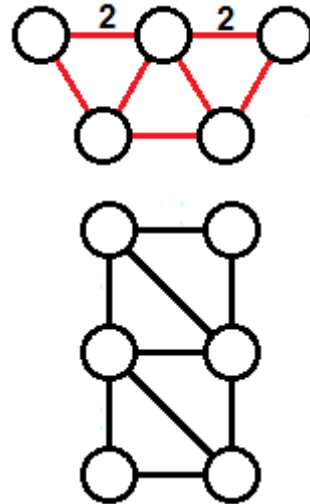
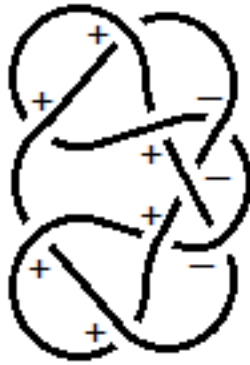

$$v_{\text{even}} = x_{9.31}$$

$$v_{\text{odd}} = \pm y_{9.31}$$

v_2	$2x_{3.1}$
v_3	$\pm 2y_{3.1}$
v_4	$-2x_{5.2} + x_{5.1} + 3x_{3.1}$
v_5	$\pm(2y_{6.2} - 2y_{6.1} - 2y_{5.2} + y_{5.1} + 3y_{3.1})$
v_6	$-5x_{7.7} - 4x_{7.5} + 2x_{7.2} + x_{7.1} + 2x_{6.3} - 6x_{6.2} + 2x_{6.1}$ $- 4x_{5.2} + x_{5.1} + 10x_{4.1} + 12x_{3.1}$

9₃₂:

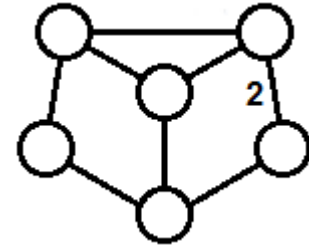
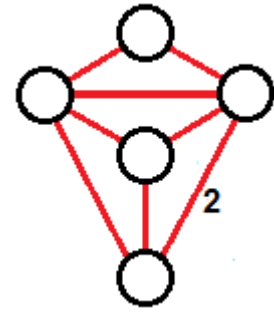
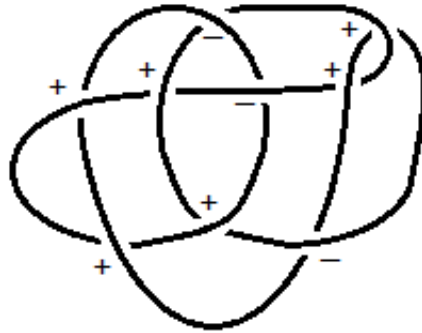

$$v_{\text{even}} = x_{9.32}$$

$$v_{\text{odd}} = \pm y_{9.32}$$

v_2	$-x_{3.1}$
v_3	$\mp 2y_{3.1}$
v_4	$-2x_{5.2} + 3x_{4.1} + 6x_{3.1}$
v_5	$\pm(3y_{6.2} - y_{6.1} - 3y_{5.2} + y_{5.1} + 4y_{3.1})$
v_6	$\frac{1}{8}(4x_{7.7} - x_{7.6} - 18x_{7.5} - 4x_{7.3} + 3x_{7.2} + 8x_{7.1} + 7x_{6.3} - 9x_{6.2} + 10x_{6.1} + 46x_{5.2} - 17x_{5.1} + 7x_{4.1} + 2x_{3.1})$

9₃₃:

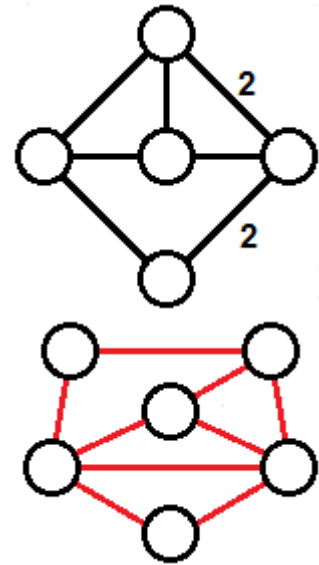
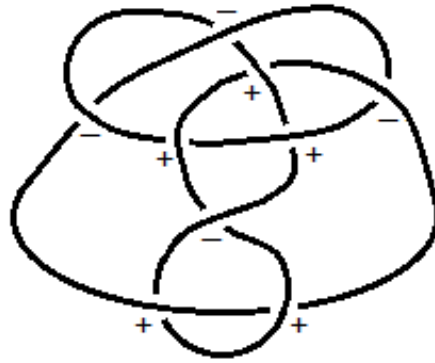

$$v_{\text{even}} = x_{9.33}$$

$$v_{\text{odd}} = \pm y_{9.33}$$

v_2	$x_{3.1}$
v_3	$\pm y_{3.1}$
v_4	$x_{3.1}$
v_5	$\mp(5y_{6.2} - 6y_{6.1} - 4y_{5.2} + 2y_{5.1})$
v_6	$\frac{1}{8}(-36x_{7.7} + 15x_{7.6} - 2x_{7.5} + 12x_{7.3} + 3x_{7.2} - 8x_{7.1} - x_{6.3} - 25x_{6.2} + 18x_{6.1} - 122x_{5.2} + 47x_{5.1} - 9x_{4.1} + 50x_{3.1})$

9₃₄:

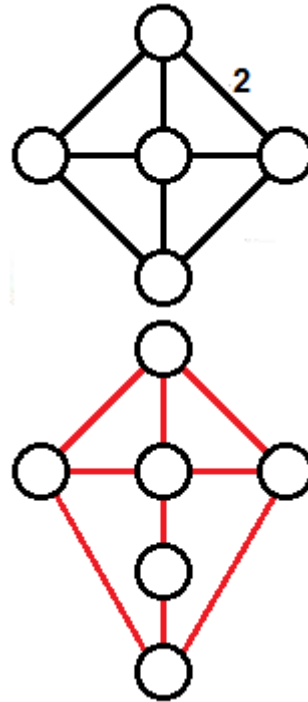
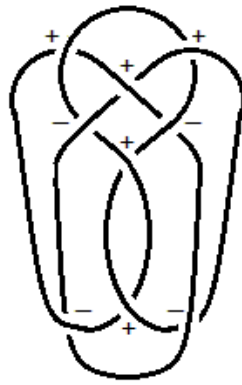

$$v_{even} = x_{9.34}$$

$$v_{odd} = \pm y_{9.34}$$

v_2	$-x_{3.1}$
v_3	0
v_4	$x_{4.1}$
v_5	$\mp(5y_{6.2} - 6y_{6.1} - 4y_{5.2} + 2y_{5.1} + y_{3.1})$
v_6	$\frac{1}{8}(-36x_{7.7} + 15x_{7.6} - 2x_{7.5} + 12x_{7.3} + 3x_{7.2} - 8x_{7.1} - x_{6.3} - 25x_{6.2} + 18x_{6.1} - 122x_{5.2} + 47x_{5.1} - x_{4.1} + 42x_{3.1})$

9₃₅:

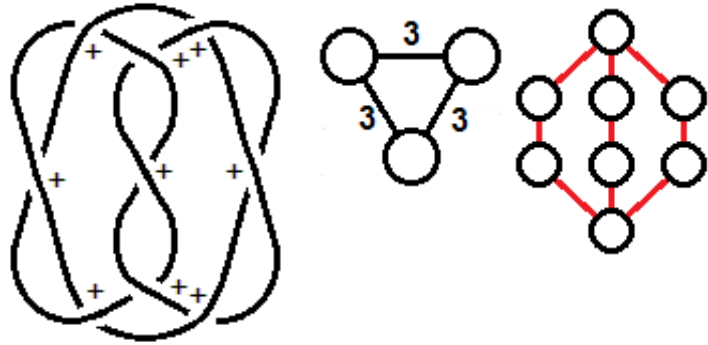

$$v_{\text{even}} = x_{9.35}$$

$$v_{\text{odd}} = \pm y_{9.35}$$

v_2	$7x_{3.1}$
v_3	$\pm 18y_{3.1}$
v_4	$12x_{5.2} + 9x_{4.1} - 8x_{3.1}$
v_5	$\pm(12y_{6.1} + 24y_{5.2} - 42y_{3.1})$
v_6	$-38x_{7.7} + 17x_{7.6} - 16x_{7.5} + 15x_{7.3} + 15x_{6.3} - 46x_{6.2}$ $+ 17x_{6.1} - 51x_{5.2} - 4x_{5.1} + 63x_{4.1} + 91x_{3.1}$

9₃₆:

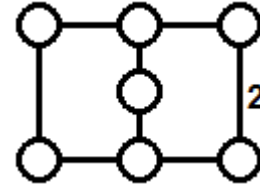
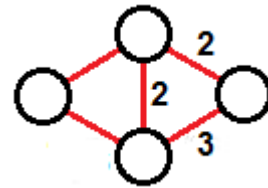
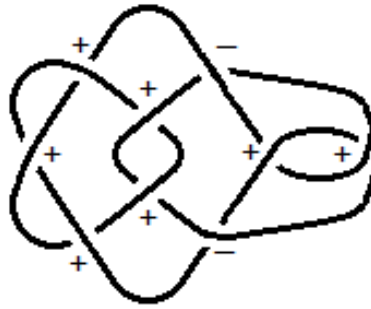

$$v_{\text{even}} = x_{9.36}$$

$$v_{\text{odd}} = \pm y_{9.36}$$

v_2	$3x_{3.1}$
v_3	$\pm 7y_{3.1}$
v_4	$8x_{5.2} - x_{5.1} - 2x_{4.1} - 12x_{3.1}$
v_5	$\pm(y_{6.2} - 4y_{6.1} + 8y_{5.2} - 20y_{3.1})$
v_6	$\frac{1}{8}(92x_{7.7} - 19x_{7.6} + 42x_{7.5} - 12x_{7.3} + 9x_{7.2} - 8x_{7.1} - 43x_{6.3} + 101x_{6.2} - 42x_{6.1} + 34x_{5.2} + 5x_{5.1} - 131x_{4.1} - 106x_{3.1})$

9₃₇:

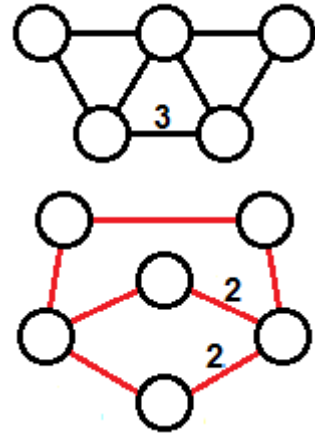
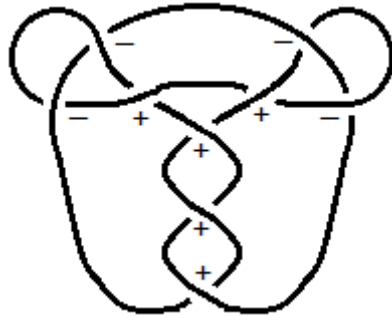

$$v_{\text{even}} = x_{9.37}$$

$$v_{\text{odd}} = \pm y_{9.37}$$

v_2	$-3x_{3.1}$
v_3	$\pm y_{3.1}$
v_4	$-5x_{5.2} + 2x_{5.1} + 5x_{4.1} + 6x_{3.1}$
v_5	$\mp(3y_{6.2} - 2y_{6.1} - 2y_{5.2} + y_{5.1} + y_{3.1})$
v_6	$2x_{7.7} + x_{7.6} - x_{6.3} - 2x_{6.2} + 3x_{6.1} - x_{5.2} - 2x_{4.1} + 3x_{3.1}$

9₃₈:

$$v_{\text{even}} = x_{9.38}$$

$$v_{\text{odd}} = \pm y_{9.38}$$

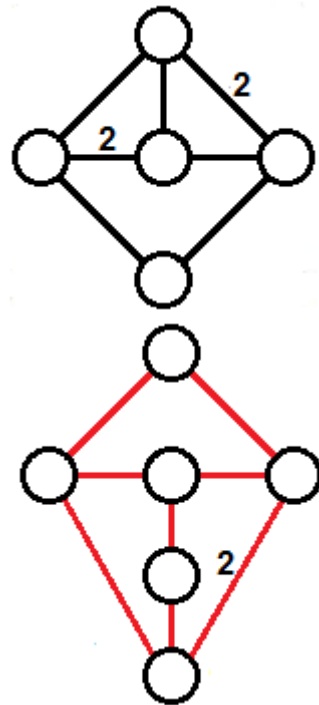
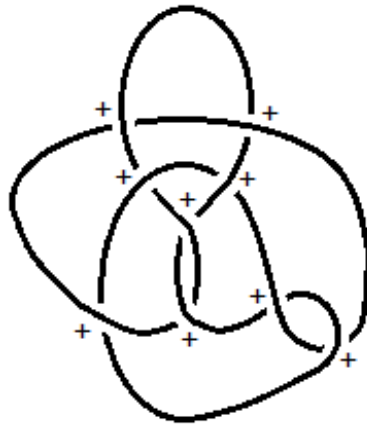

v_2	$6x_{3.1}$
v_3	$\pm 14y_{3.1}$
v_4	$5x_{5.1} - 9x_{3.1}$
v_5	$\mp(5y_{6.2} - 6y_{6.1} - 4y_{5.2} - 5y_{5.1} + 22y_{3.1})$
v_6	$\frac{1}{8}(-108x_{7.7} + 71x_{7.6} - 10x_{7.5} + 32x_{7.3} - 17x_{7.2} + 47x_{6.3} - 117x_{6.2} + 54x_{6.1} - 182x_{5.2} + 11x_{5.1} + 123x_{4.1} + 198x_{3.1})$

9₃₉:

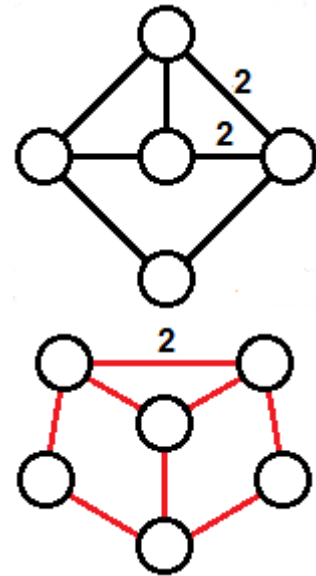
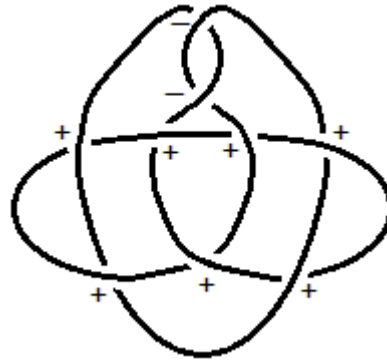

$$v_{\text{even}} = x_{9.39}$$

$$v_{\text{odd}} = \pm y_{9.39}$$

v_2	$2x_{3.1}$
v_3	$\pm 4y_{3.1}$
v_4	$8x_{5.2} - 3x_{5.1} + 2x_{4.1} - 3x_{3.1}$
v_5	$\mp(y_{6.2} - 2y_{6.1} - 10y_{5.2} + 3y_{5.1} + 10y_{3.1})$
v_6	$\frac{1}{8}(-68x_{7.7} + 23x_{7.6} - 26x_{7.5} + 16x_{7.3} + 15x_{7.2} + 15x_{6.3} - 69x_{6.2} + 22x_{6.1} - 102x_{5.2} + 3x_{5.1} + 123x_{4.1} + 182x_{3.1})$

9₄₀:

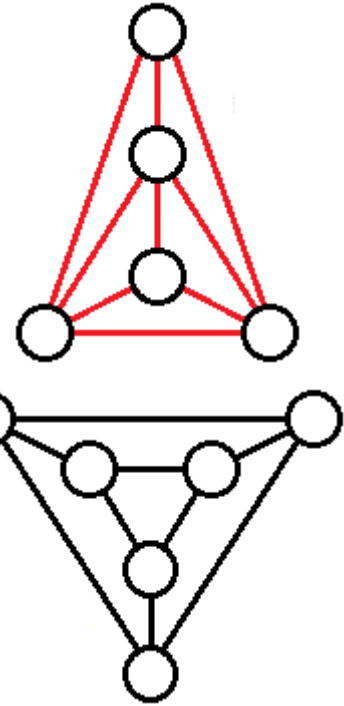
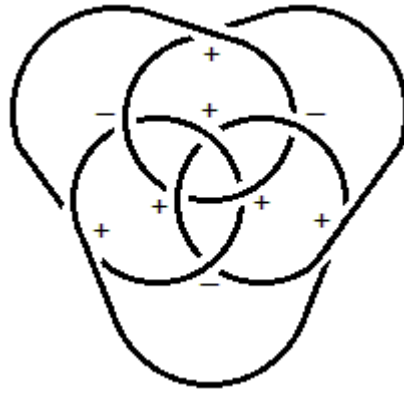

$$v_{even} = x_{9.40}$$

$$v_{odd} = \pm y_{9.40}$$

v_2	$-x_{3.1}$
v_3	$\mp y_{3.1}$
v_4	$x_{5.2} - x_{5.1} + 3x_{4.1} + 3x_{3.1}$
v_5	$\pm(6y_{6.2} - 6y_{6.1} - 4y_{5.2} + 2y_{5.1} + y_{3.1})$
v_6	$\frac{1}{8}(-4x_{7.7} - 15x_{7.6} - 22x_{7.5} - 8x_{7.3} + 17x_{7.2} + 8x_{7.1} - 7x_{6.3} - 3x_{6.2} + 2x_{6.1} + 14x_{5.2} + 5x_{5.1} + 21x_{4.1} + 18x_{3.1})$

9₄₁:

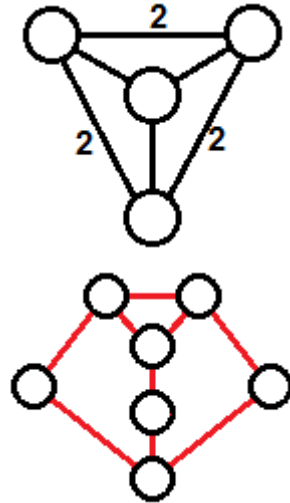
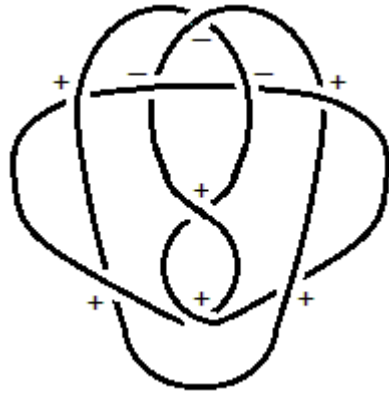

$$v_{\text{even}} = x_{9.41}$$

$$v_{\text{odd}} = \pm y_{9.41}$$

v_2	0
v_3	$\mp y_{3.1}$
v_4	$-6x_{5.2} + 3x_{5.1} - 3x_{4.1}$
v_5	$\pm(6y_{6.2} - 8y_{6.1} - 9y_{5.2} + 4y_{5.1} + 4y_{3.1})$
v_6	$\frac{1}{8}(140x_{7.7} - 41x_{7.6} + 46x_{7.5} - 24x_{7.3} - 17x_{7.2} - 25x_{6.3} + 131x_{6.2} - 58x_{6.1} + 210x_{5.2} - 45x_{5.1} - 157x_{4.1} - 234x_{3.1})$

9₄₂:

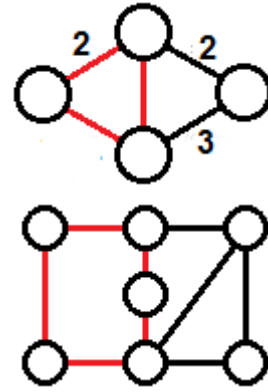

$$v_{\text{even}} = x_{9.42}$$

$$v_{\text{odd}} = \pm y_{9.42}$$

v_2	$-2x_{3.1}$
v_3	0
v_4	$x_{5.2} - x_{5.1} + 5x_{4.1} + 4x_{3.1}$
v_5	0
v_6	$\frac{1}{8}(-36x_{7.7} + 13x_{7.6} - 14x_{7.5} + 4x_{7.3} + 9x_{7.2} + 5x_{6.3} - 27x_{6.2} + 22x_{6.1} - 78x_{5.2} + 29x_{5.1} + 29x_{4.1} + 54x_{3.1})$

9₄₃:

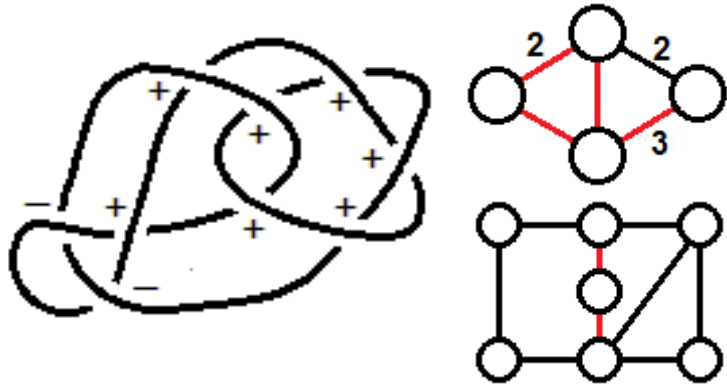

$$v_{\text{even}} = x_{9.43}$$

$$v_{\text{odd}} = \pm y_{9.43}$$

v_2	$x_{3.1}$
v_3	$\pm 2y_{3.1}$
v_4	$7x_{5.2} - 3x_{5.1} + 2x_{4.1} - 2x_{3.1}$
v_5	$\pm(6y_{6.2} - 7y_{6.1} + 3y_{5.2} - 8y_{3.1})$
v_6	$\frac{1}{8}(28x_{7.7} - 35x_{7.6} + 10x_{7.5} - 4x_{7.3} + 25x_{7.2} - 8x_{7.1} - 35x_{6.3}$ $+ 69x_{6.2} - 34x_{6.1} - 54x_{5.2} + 45x_{5.1} - 51x_{4.1} - 18x_{3.1})$

9₄₄:

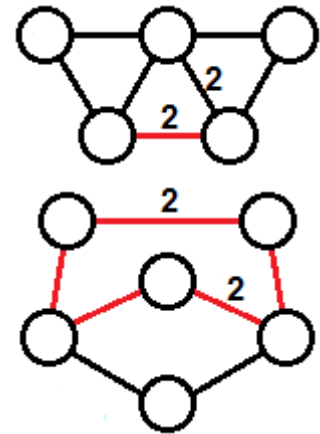
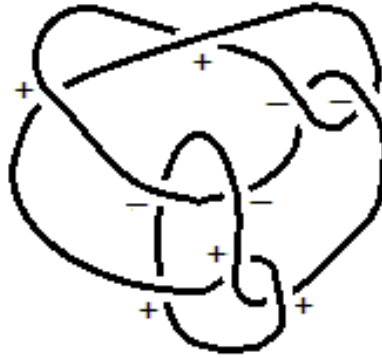

$$v_{\text{even}} = x_{9.44}$$

$$v_{\text{odd}} = \pm y_{9.44}$$

v_2	0
v_3	$\pm y_{3.1}$
v_4	$-x_{5.2} + x_{5.1} - 2x_{4.1} - 3x_{3.1}$
v_5	$\mp(3y_{6.2} - 3y_{6.1} - 2y_{5.2} + y_{5.1})$
v_6	$\frac{1}{8}(28x_{7.7} + 5x_{7.6} + 10x_{7.5} - 4x_{7.3} - 7x_{7.2} + 5x_{6.3} + 21x_{6.2} - 10x_{6.1} + 42x_{5.2} - 11x_{5.1} - 27x_{4.1} - 58x_{3.1})$

9₄₅:

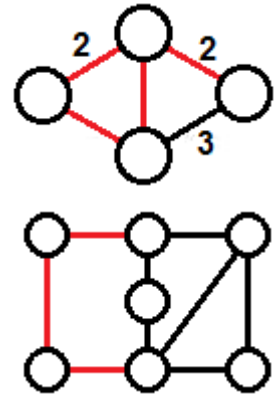
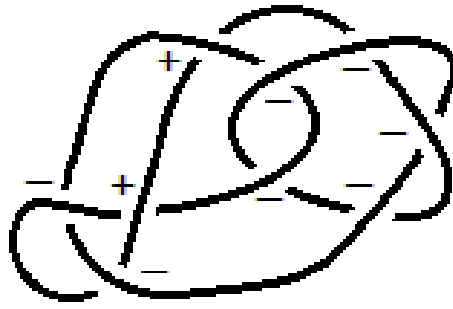

$$v_{\text{even}} = x_{9.45}$$

$$v_{\text{odd}} = \pm y_{9.45}$$

v_2	$2x_{3.1}$
v_3	$\mp 4y_{3.1}$
v_4	$5x_{5.2} - x_{5.1} - x_{4.1} - 6x_{3.1}$
v_5	$\mp (2y_{6.2} - 4y_{6.1} + 4y_{5.2} - 10y_{3.1})$
v_6	$\frac{1}{8}(52x_{7.7} - 27x_{7.6} + 18x_{7.5} - 12x_{7.3} + 9x_{7.2} - 19x_{6.3} + 61x_{6.2} - 34x_{6.1} + 74x_{5.2} - 19x_{5.1} - 35x_{4.1} - 58x_{3.1})$

9₄₆:

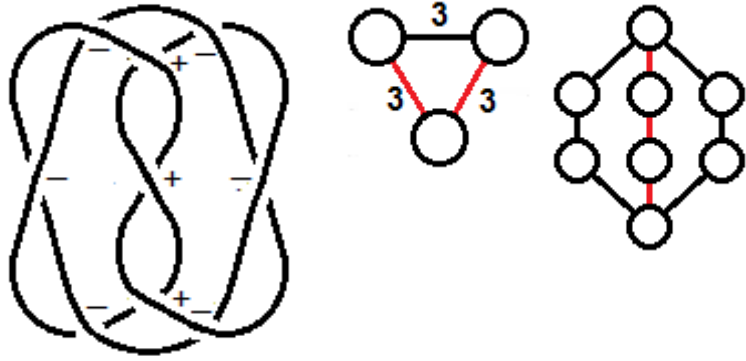

$$v_{\text{even}} = x_{9.46}$$

$$v_{\text{odd}} = \pm y_{9.46}$$

v_2	$-2x_{3.1}$
v_3	$\pm 3y_{3.1}$
v_4	$-3x_{5.2} + 6x_{4.1} + 10x_{3.1}$
v_5	$\mp(4y_{6.1} - y_{5.2} + 4y_{3.1})$
v_6	$-3x_{7.7} + 3x_{7.6} - 2x_{7.5} + x_{7.3} + x_{6.3} - 4x_{6.2}$ $+ 5x_{6.1} - 8x_{5.2} + 3x_{5.1} - 4x_{4.1} + 3x_{3.1}$

9₄₇:

$$v_{\text{even}} = x_{9.47}$$

$$v_{\text{odd}} = \pm y_{9.47}$$

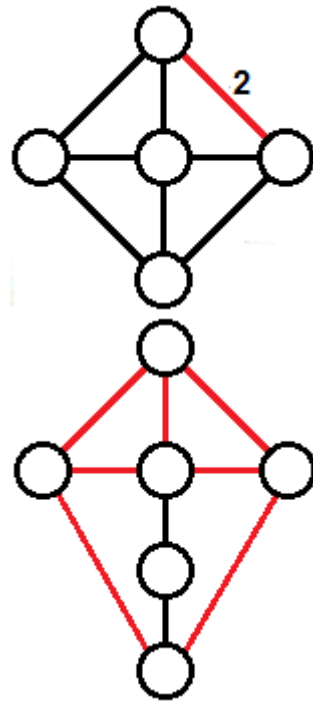
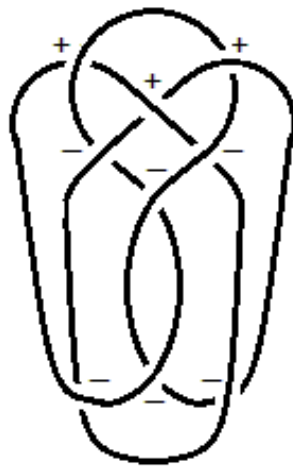

v_2	$-x_{3.1}$
v_3	$\pm 2y_{3.1}$
v_4	$-5x_{5.2} + 2x_{5.1} + 3x_{3.1}$
v_5	$\mp(y_{6.1} - 3y_{5.2} + y_{5.1} + 3y_{3.1})$
v_6	$\frac{1}{8}(44x_{7.7} - 3x_{7.6} + 2x_{7.5} - 8x_{7.3} - 11x_{7.2} + 8x_{7.1} + 5x_{6.3} + 9x_{6.2} - 6x_{6.1} + 118x_{5.2} - 55x_{5.1} + x_{4.1} - 22x_{3.1})$

9₄₈:

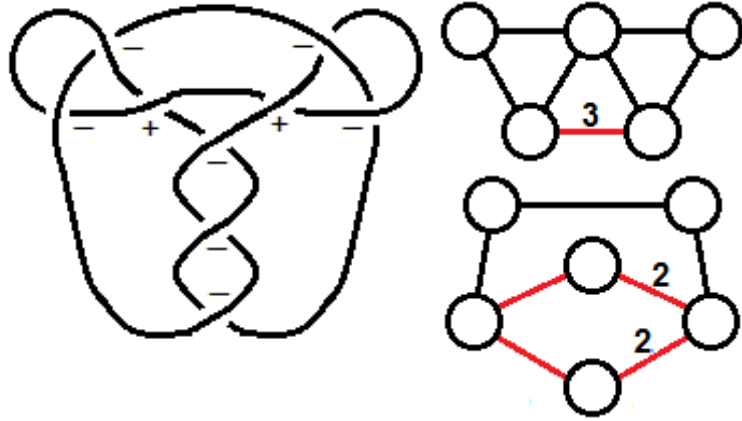

$$v_{\text{even}} = x_{9.48}$$

$$v_{\text{odd}} = \pm y_{9.48}$$

v_2	$3x_{3.1}$
v_3	$\mp 5y_{3.1}$
v_4	$3x_{5.2} - x_{5.1} + 3x_{4.1} + 3x_{3.1}$
v_5	$\pm(3y_{6.2} - 6y_{6.1} - 6y_{5.2} + 2y_{5.1})$
v_6	$-11x_{7.7} + 5x_{7.6} - 4x_{7.5} + 3x_{7.3} + 3x_{6.3} - 13x_{6.2}$ $+ 5x_{6.1} - 15x_{5.2} + x_{5.1} + 18x_{4.1} + 27x_{3.1}$

9₄₉:

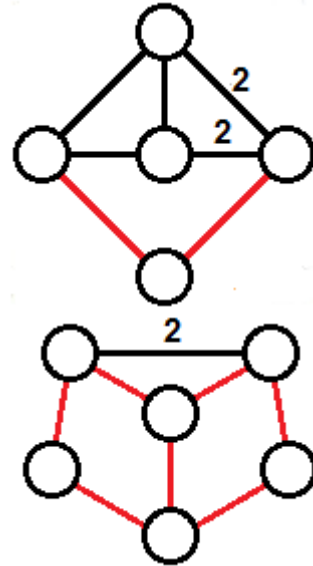
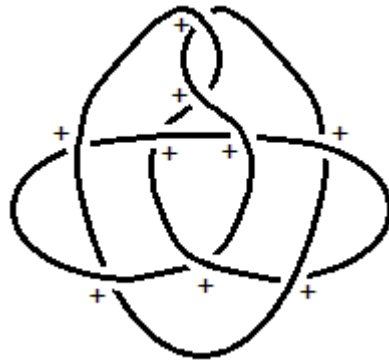

$$v_{\text{even}} = x_{9.49}$$

$$v_{\text{odd}} = \pm y_{9.49}$$

v_2	$6x_{3.1}$
v_3	$\pm 14y_{3.1}$
v_4	$3x_{5.2} + 3x_{5.1} + 3x_{4.1} - 6x_{3.1}$
v_5	$\pm(4y_{6.1} + 6y_{5.2} + 4y_{5.1} - 20y_{3.1})$
v_6	$\frac{1}{8}(-84x_{7.7} + 45x_{7.6} - 30x_{7.5} + 36x_{7.3} - 7x_{7.2} + 37x_{6.3} - 91x_{6.2} + 38x_{6.1} - 126x_{5.2} + 13x_{5.1} + 109x_{4.1} + 150x_{3.1})$